

Sensors & Applications

Battery Production



More Precision

More precision for battery film production

Micro-Epsilon offers reliable solutions for numerous measurement tasks in battery production, from high-precision distance sensors to inline thickness measuring systems and 3D sensors. These sensors are used at every production stage from electrode manufacturing to assembly and forming processes. Micro-Epsilon's extensive and diverse product portfolio offers the most suitable sensor product for every type of coating and all measuring objects.

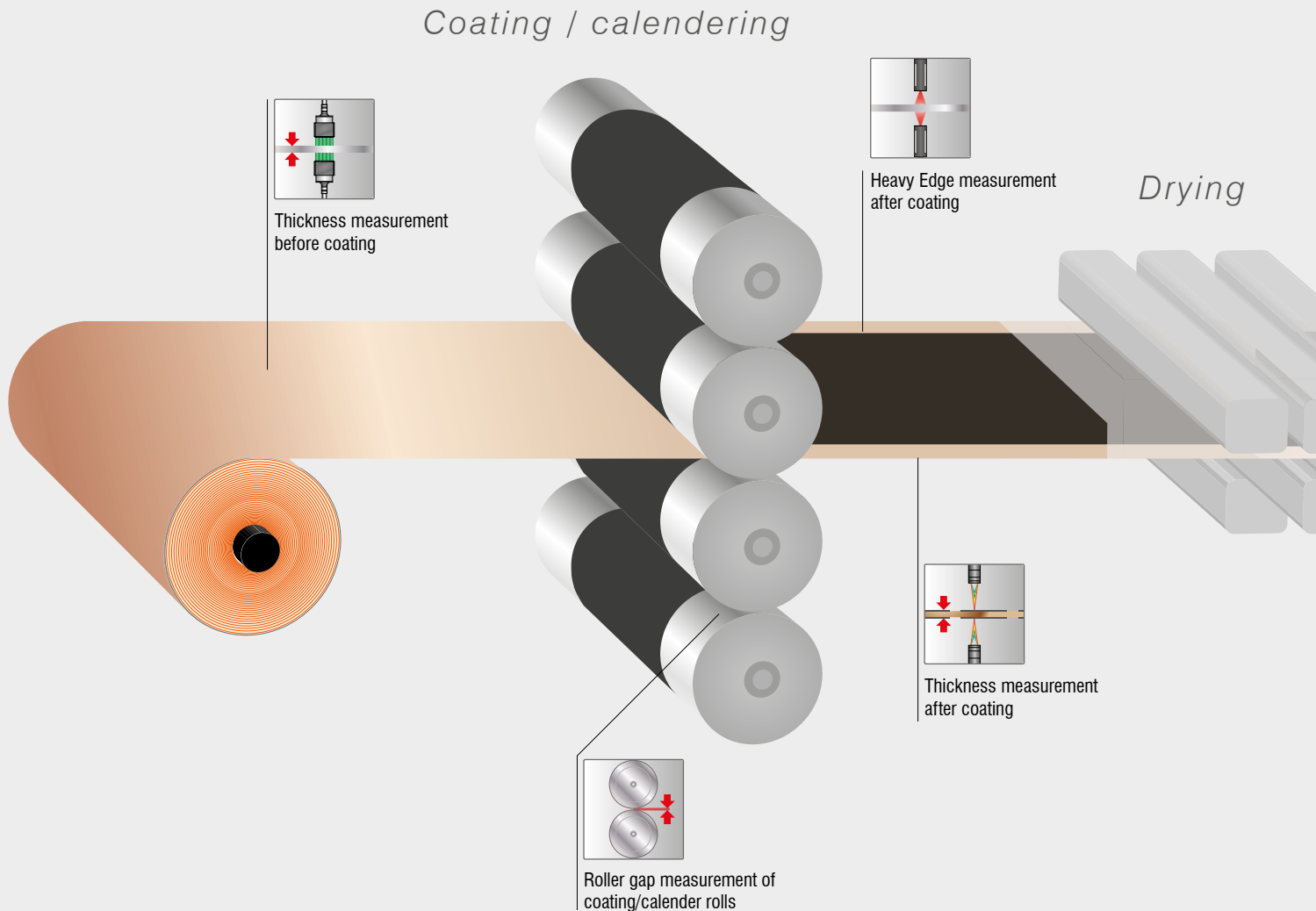

Why Micro-Epsilon?

- Increasing economic efficiency, resource conservation and quality
- Highest precision down to the submicron range
- Bundled sensor and system expertise from a single source
- Wide technology portfolio for the optimum solution for your application
- Decades of experiences in strip and belt processes



All coating types

Single-sided, double-sided, intermittent and longitudinal coating



All film types

Coated as well as uncoated aluminum, copper and separator films (plastic)

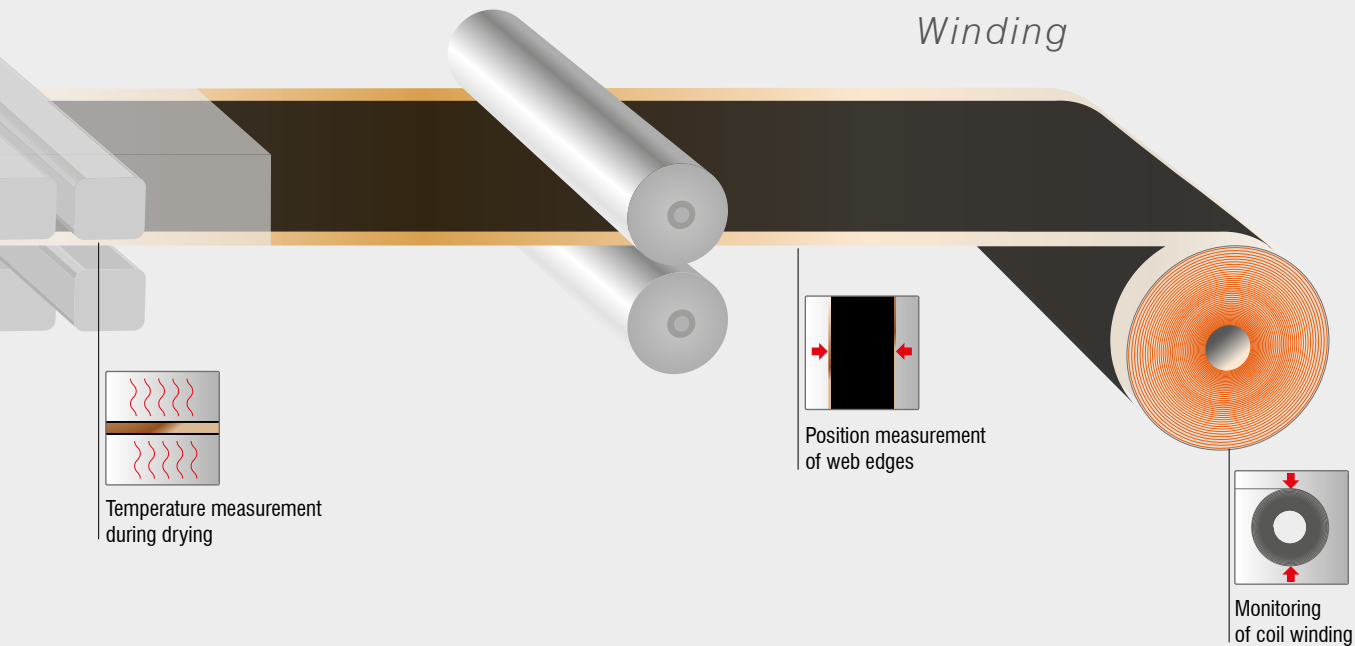

Robust systems for multi-track strip thickness measurement

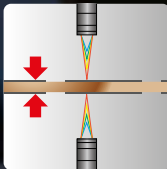

- Reliable measurement methods for all coating processes
- Ideal for fluctuating, high ambient temperatures
- Process-reliable multi-track thickness measurement

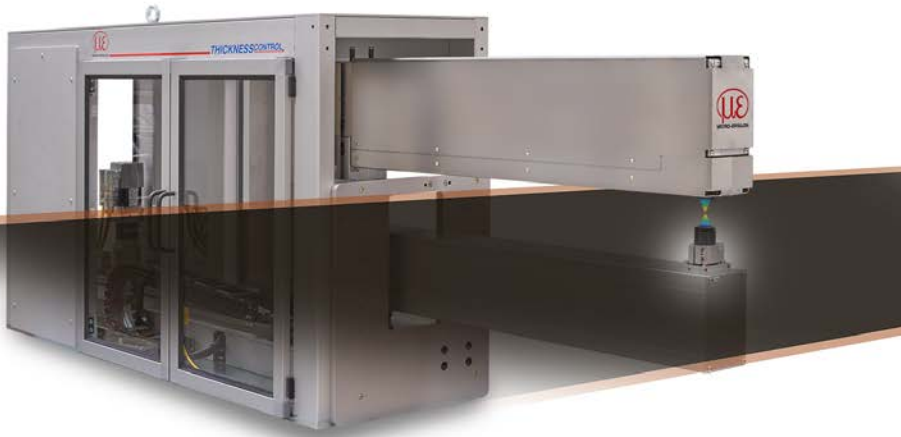

High precision inline thickness measurement of battery film

Micro-Epsilon offers precise and robust measuring systems for the precise thickness measurement of coated electrode films. The thicknessCONTROL Quad consists of two robust measuring frames, each with four confocal sensor pairs. The system is used for high-precision inline thickness measurement of coated anode and cathode films and impresses with its long-term stable measurements. Thanks to the robust and temperature-compensated design, the system delivers precise measurement results even at high ambient temperatures.

Measuring system: thicknessCONTROL

Multi-track coating thickness

The thicknessCONTROL systems can be equipped with up to 4 pairs of sensors.

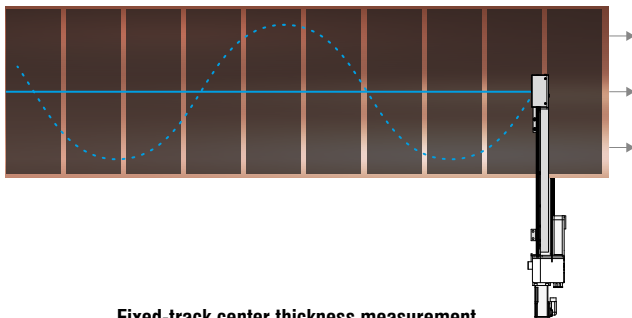

Fixed-track center thickness measurement
Traversing thickness measurement

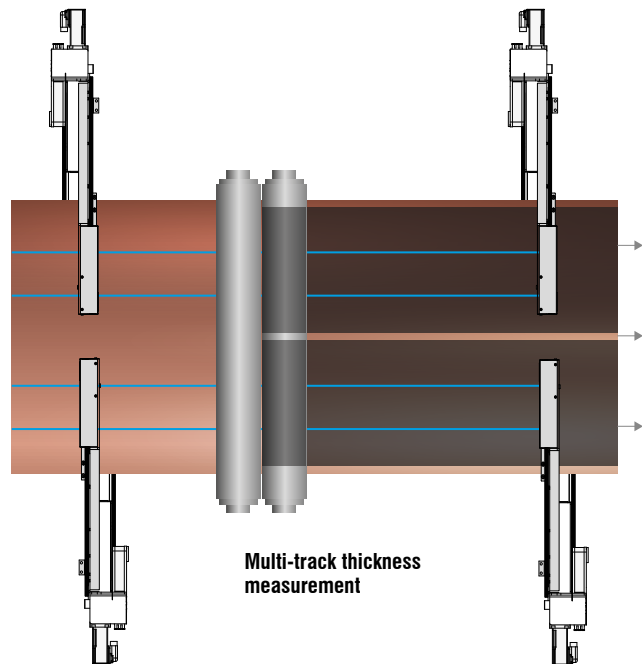

Multi-track thickness measurement

Inline system for strip thickness measurement

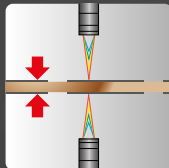

- Compact solution for precise inline thickness measurements
- For many types of surfaces and materials due to different sensor technologies

Thickness measurement with high precision

ThicknessGAUGE sensor systems are used for inline thickness measurement of strip materials. These are available with different sensor types, measuring ranges and measuring widths allowing for various materials and surfaces to be measured. The system uses two optical distance sensors or laser scanners to measure the strip thickness. The sensors are precisely aligned to each other and factory-calibrated. By means of a linear axis, the thicknessGAUGE sensor systems can be moved to measure the thickness over the entire strip width.

Measuring system: thicknessGAUGE

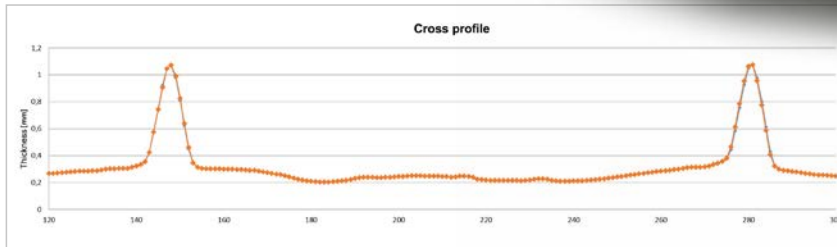

Thickness profile evaluation

If the sensor is moved over the strip material by means of a linear axis, transverse thickness profiles can be evaluated.

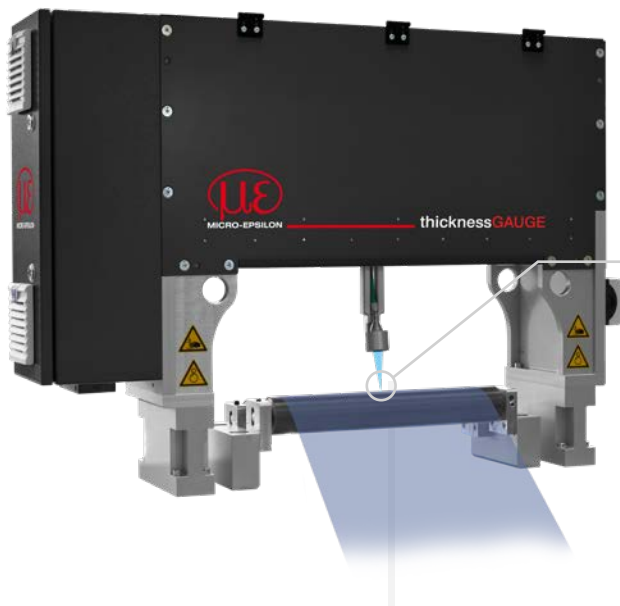

The thicknessGAUGE sensor systems combine high-precision sensors with a coordinated mechanical system including a traversing axis. Thanks to a comprehensive software and interface package, the sensor systems can be integrated into production lines in a process-safe manner.

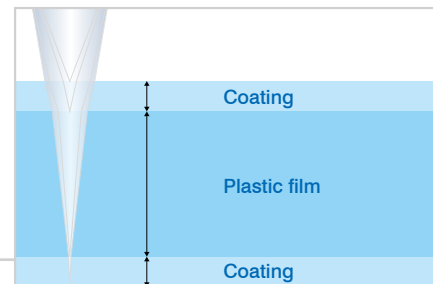

Compact measuring system for inline thickness measurement of separator films

The compact thicknessGAUGE sensor system is used for coating thickness measurement of separator film. Equipped with a white light interferometer, the sensor system detects both the film thickness and the coating from 10 μm thickness.

Measuring system: thicknessGAUGE O.IMS

Stable thickness measurement using capacitive sensors

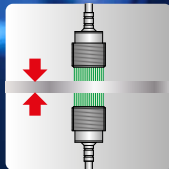

- Precise measurements even at ambient temperatures of up to 200 °C
- Multi-channel controller for multi-track measurements
- Large measurement spot compensates for inhomogeneous structures

Thickness measurement using capacitive sensors

Two capacitive sensors mounted opposite each other enable high-precision thickness measurement of battery films with and without coating. Each sensor provides a linear distance signal which is calculated by the controller as a thickness measurement value. The measuring spot of the sensors is larger than that of the optical methods, which eliminates any structures and anomalies on the surface. Using the capaNCDT multi-channel controllers enables processing of several sensor pairs with just one controller. Thanks to integrated temperature compensation, the sensors are extremely temperature-stable and are therefore also used in dry coating processes.

Sensor: capaNCDT 6200

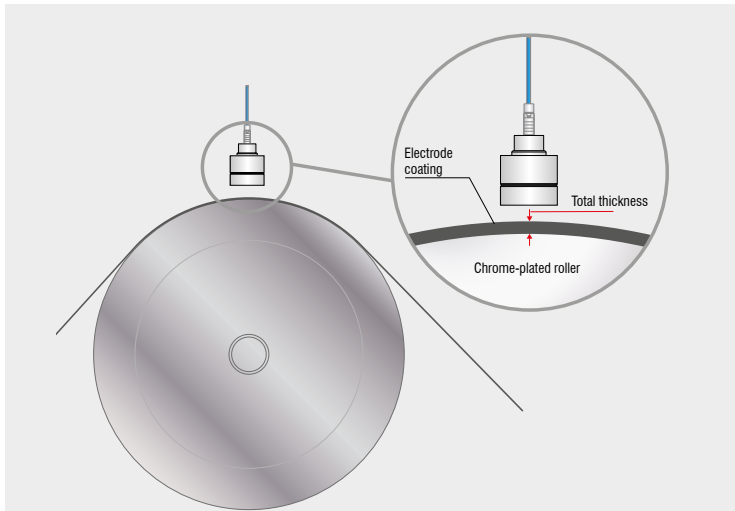

Sensor system for thickness measurement of electrode coatings

For stable thickness measurement in dirty areas with high ambient temperatures, the combiSENSOR is used, which measures the thickness without contact from only one side. The roller serves as a reference target for the integrated eddy current sensor, while the capacitive sensor measures the distance to the electrode coating. The total thickness of the coated film is calculated by the controller from both signals and output as a measured value.

Measuring system: combiSENSOR



Thickness measuring system for battery films

The capaNCDT TFG6220 is used to determine the film thickness. The capacitive measuring system measures the thickness of the battery films with maximum precision. A vacuum device sucks in the film and thus ensures wrinkle-free support. In this way, the thickness measurement is highly reproducible. The TFG6220 is used for offline quality inspection and referencing of films.

Measuring system: capaNCDT TFG6220

Sensor systems for 3D measurements

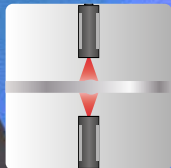
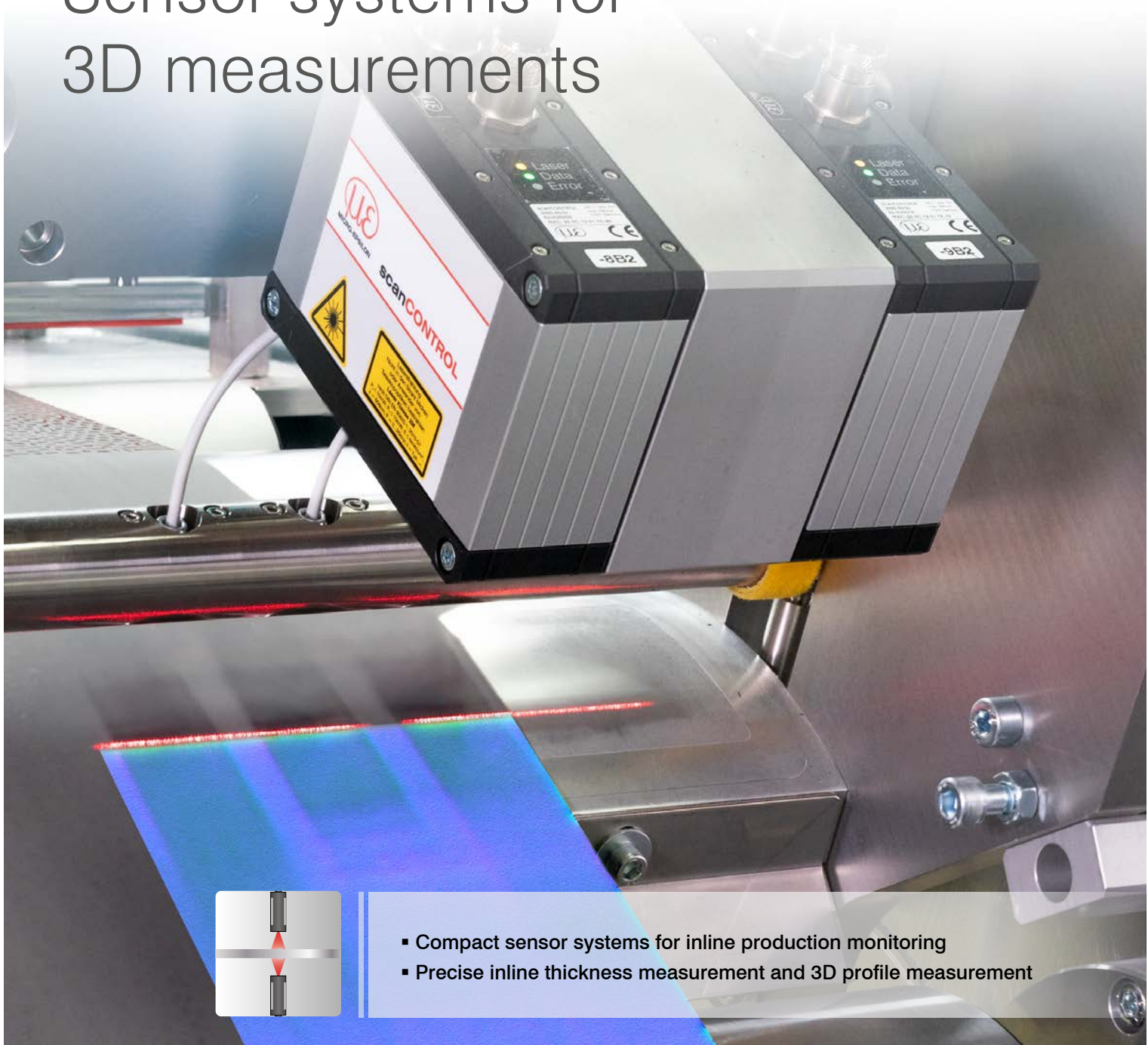

- Compact sensor systems for inline production monitoring
- Precise inline thickness measurement and 3D profile measurement

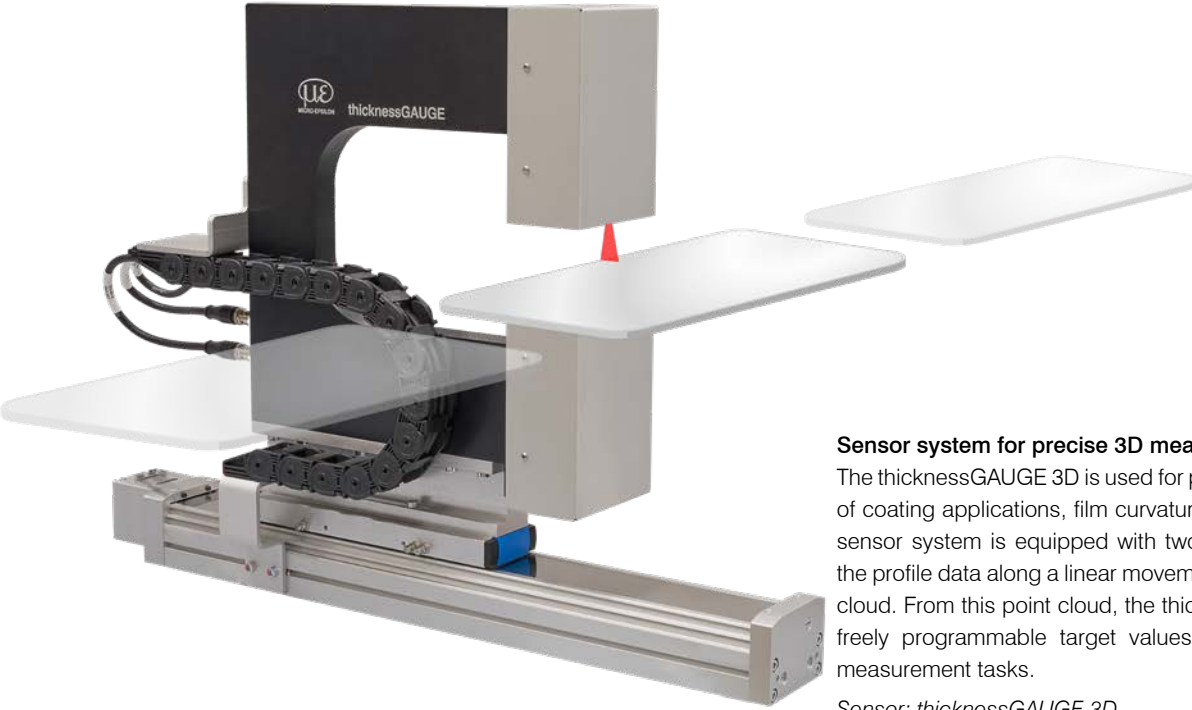

Sensor system for precise 3D measurements

The thicknessGAUGE 3D is used for precise inline 3D measurements of coating applications, film curvature and welded pouch cells. The sensor system is equipped with two laser scanners. These detect the profile data along a linear movement and merge it into a 3D point cloud. From this point cloud, the thicknessCONTROL 3D calculates freely programmable target values to solve complex 2D or 3D measurement tasks.

Sensor: thicknessGAUGE 3D

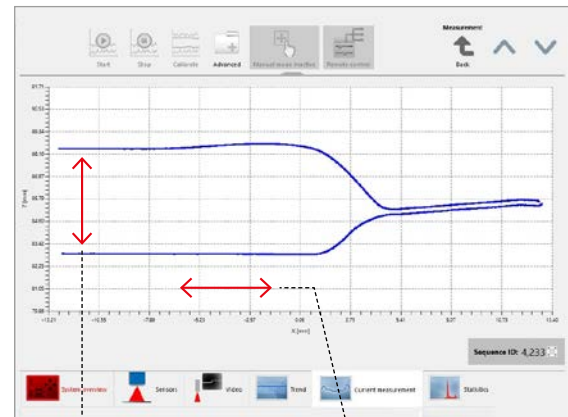
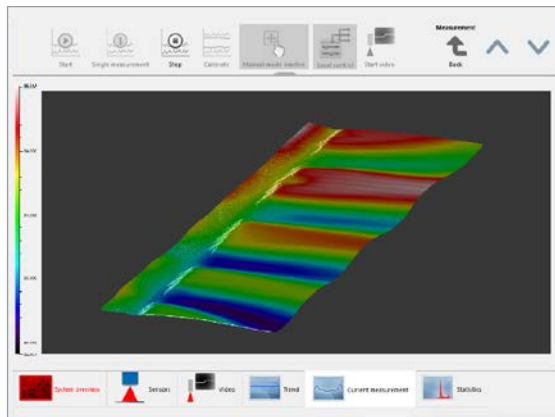

Thickness calculation

Profile evaluation possible

Dynamic thickness measurement with optical sensors

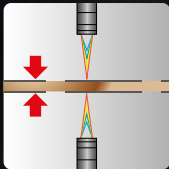

- Reliable measurement methods for all coating processes
- High repeatability and high measuring rate
- Ideal for dynamic process control

High-precision optical sensors for two-sided thickness measurement

Micro-Epsilon offers a comprehensive sensor portfolio for two-sided thickness measurement with optical sensors. Two sensors are arranged opposite each other and measure the distance to the battery film. This arrangement allows extremely high resolution to be achieved.

In addition to confocal chromatic sensors, laser triangulation sensors are particularly suitable, which are selected depending on the accuracy requirements, surface type and coating type (uncoated/coated). The sensors are usually used to monitor and control coating processes.

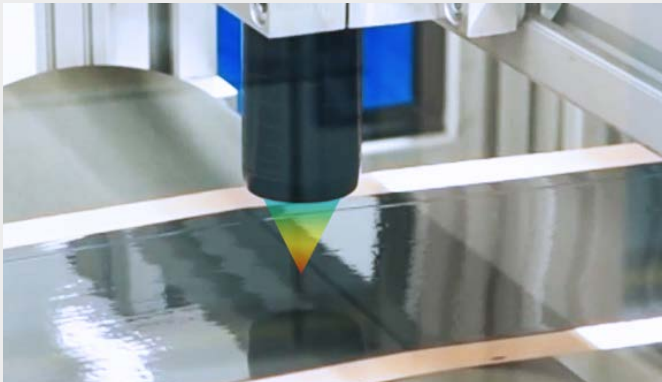
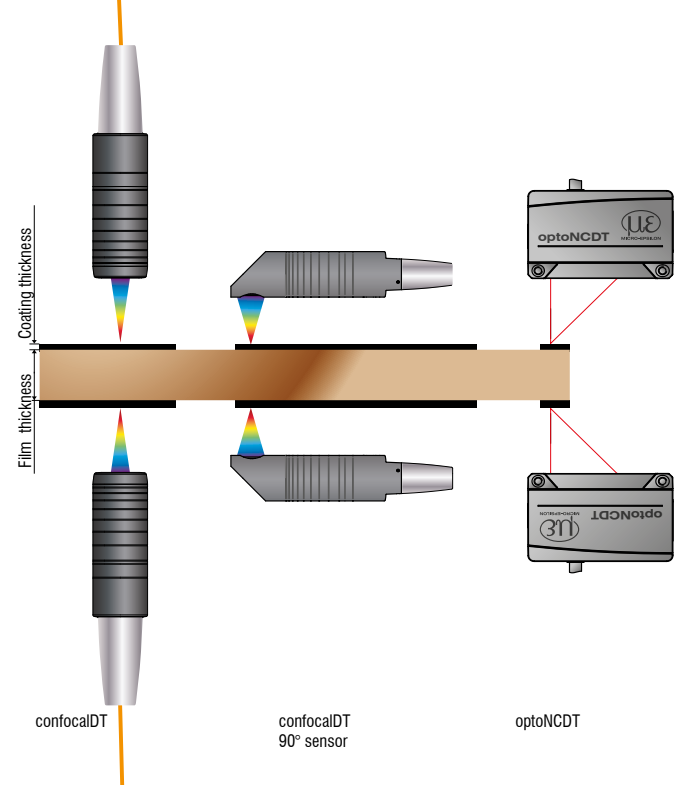

Measuring the thickness of wet layers

Confocal chromatic sensors from Micro-Epsilon monitor the coating thickness of wet materials. These sensors provide both extremely high resolution and high measuring rates. Installing several sensors next to each other enables concurrent determination of the homogeneity of the coating over the complete strip width.

Sensor: *confocalDT*

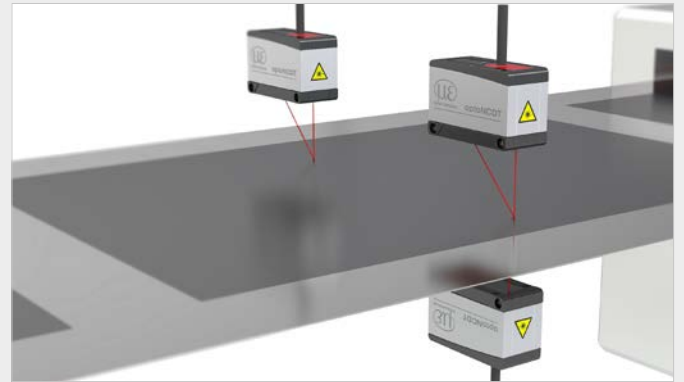

Thickness measurement of electrode coatings

Laser sensors arranged opposite each other measure the thickness of coated electrodes. The two sensors each detect the distance to the battery film with high resolution. The thickness value, which is used for coating control and quality assurance, is calculated from both signals. In addition, the compact sensors are tight and robust. Thanks to their high degree of protection, a long service life is achieved.

Sensor: *optoNCDT 1900LL*

Non-contact sensors for machine monitoring

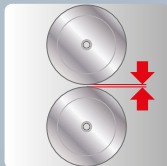

- Optimized sensors for integration into machines and systems
- High accuracy and temperature stability
- Ideal for machine monitoring

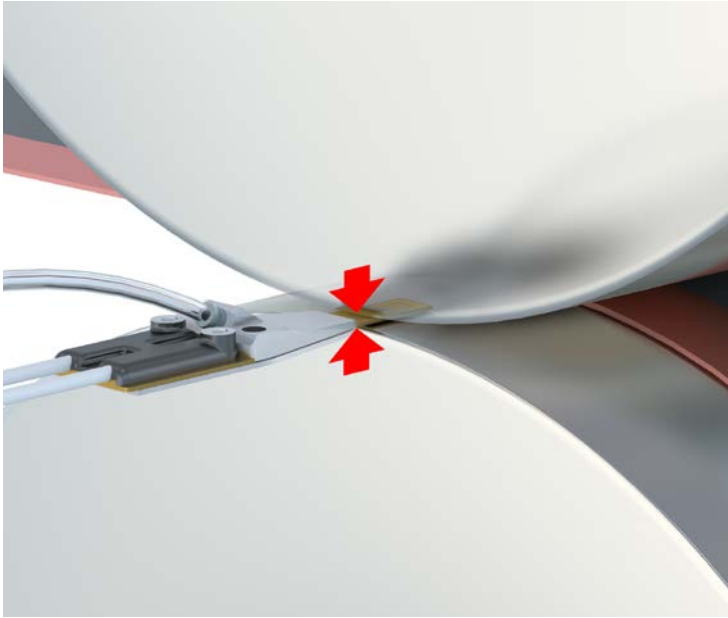

Precise control of the roller gap

Capacitive flat sensors are used for gap monitoring and control of calender and coating rollers. These are available in various designs and detect the roller gap with micrometer accuracy. The sensors are optimized for integration in confined installation spaces and measure between two rollers. The roller gap is controlled during operation based on the measured values. In addition, the temperature-stable design allows use even at high ambient temperatures. An integrated air purge protects the sensor from dust deposits.

Sensor: *capaNCDT CSG*



Precise measurement of the bearing gap

Capacitive flat sensors are used to determine the wear of rollers. The roll wear is measured indirectly via the change in the bearing gap of the drive shaft. The capacitive sensors measure continuously and with high precision. As a result, wear is permanently determined and detected at an early stage, which means that maintenance intervals can be scheduled in a targeted manner. The capacitive sensors can also be used with strong temperature fluctuations and provide a high signal stability.

Sensor: *capaNCDT*

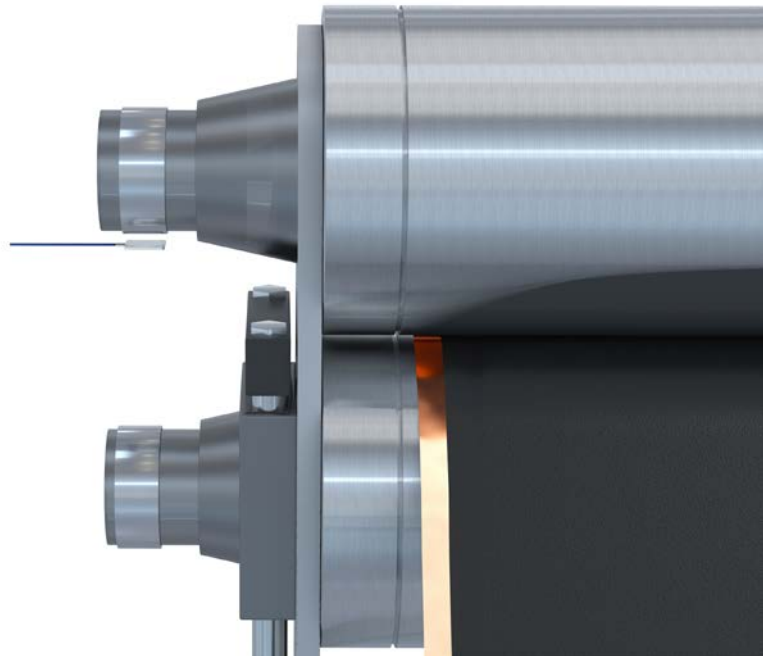

Capacitive flat sensors: Stable measurement with micrometer accuracy



Precise sensors for process monitoring

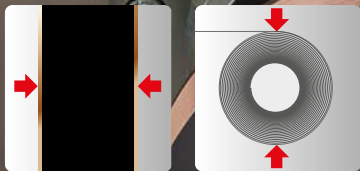

- Reliable sensors for battery film monitoring
- Ideal for fully automatic control of electrode production

Web edge control of electrode film

During the production of battery cells, electrode and separator films must be guided reliably. Optical optoCONTROL micrometers detect the required edge position for web edge control with high accuracy. Operating several micrometers enables the concurrent detection of the web width.

Sensor: *optoCONTROL 2700*

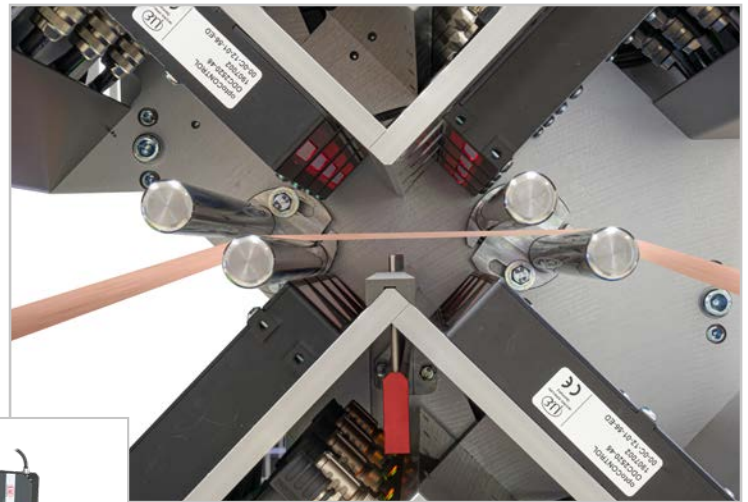
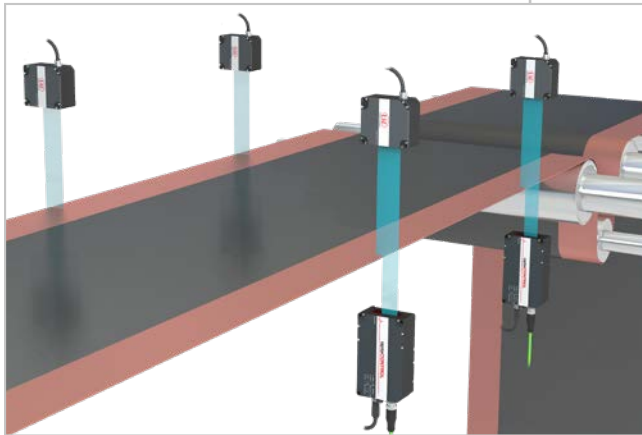

Detection of web edges and width measurement

Monitoring the coil unwinding process

optoNCDT ILR2250-100 laser distance sensors monitor the winding and unwinding of coils. As the diameter continuously increases or decreases respectively, the distance between the coil and the sensor changes. This distance change is reliably and precisely monitored by the sensors. The integrated AUTO measurement mode enables reliable detection even on reflective surfaces and mat coatings.

Sensor: *optoNCDT ILR2250*

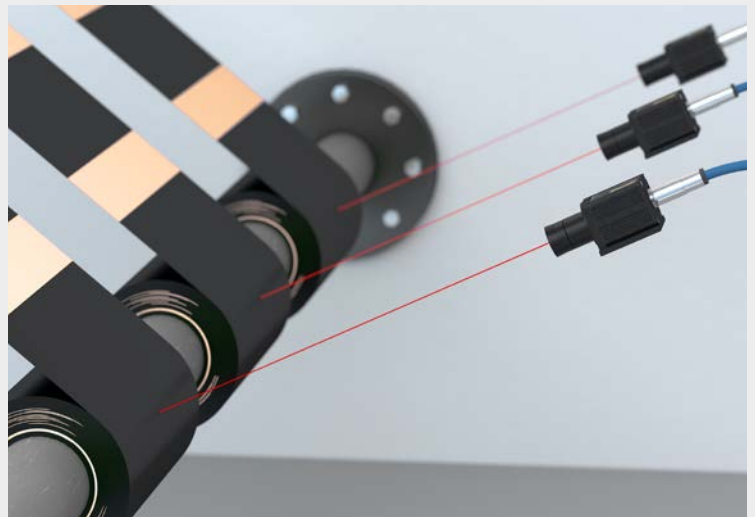

Precise sensors for production monitoring

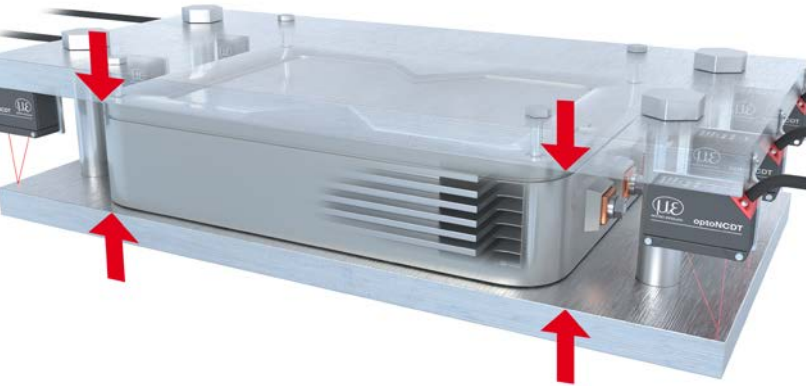

Measurement of battery expansion during charging

When the battery is first charged, the battery cell expands. To detect the critical point before rupture and to interrupt the charging process, the battery is installed in a test stand. Laser sensors from Micro-Epsilon check the vertical expansion in several charge and discharge cycles. The compact sensors can also be accommodated in confined spaces and deliver high measurement accuracy.

Sensor: *optoNCDT 1420*



Inspection of adhesive beading and applied sealants

scanCONTROL laser scanners inspect the presence and dimension of adhesive beading. They are mounted on the dispenser and control the quantity applied and the distance from the dispenser. Their high resolution enables them to reliably detect even the finest of beads. This is how breaks and flaws can be detected regardless of the type of application or the color applied.

Sensor: *scanCONTROL*

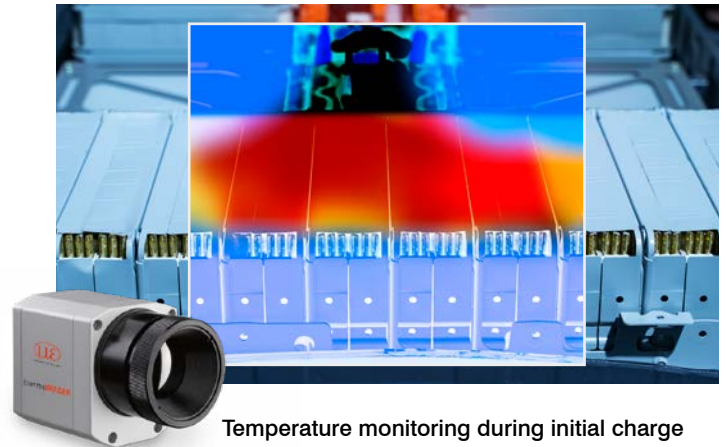

Temperature monitoring during initial charge

Thermal imaging cameras from Micro-Epsilon monitor the initial charge of battery cells. They provide an insight into the temperature distribution and any possible short circuits. In addition, they are used for early fire detection. The hot-spot detection feature automatically recognizes and outputs deviations from the target temperature.

Sensor: *thermoIMAGER*

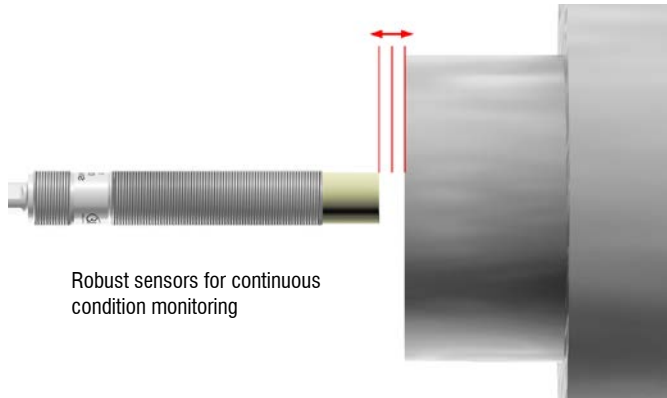

Robust sensors for continuous condition monitoring

Precise measurement of the axial roll runout

In order to enable the guide or coating rolls to operate at the highest precision, the axial roll runout is continuously measured. For this purpose, eddy current displacement sensors detect the axial movement of the roll by determining the distance to the roll. In addition to the compact design, the advantage of the eddy current sensors used is their resistance to harsh environments: the sensors provide precise measurement results even when oil, dirt, temperatures or pressure act on the sensor. The compact eddyNCDT 3001 sensors also have an integrated controller, which further facilitates integration.

Sensor: *eddyNCDT 3001*

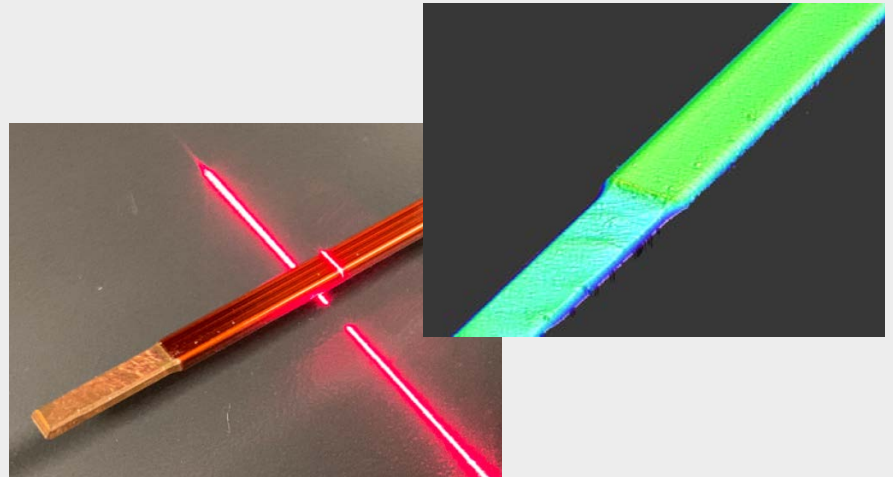
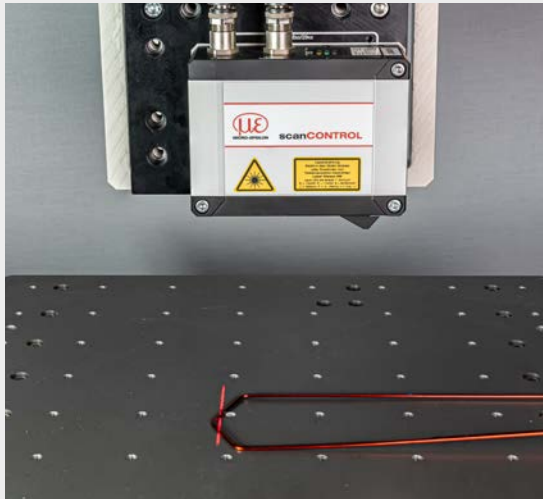

2D/3D geometry inspection of hairpins

Hairpin technology makes it possible to pack wires more densely and thus increase the power and torque in electric motors. During the production of the copper wires, various geometric parameters such as the cross-section of the wire, bending angle and parallelism are checked. Possible defects on the component and the position of the connecting wires are also monitored to ensure perfect functioning. 3D sensors and laser scanners are used for geometric checks. These inspect geometry, defects and positioning to ensure perfect function.

Sensor: *scanCONTROL / surfaceCONTROL 3500*

Sensors and Systems from Micro-Epsilon



Sensors and systems for displacement, distance and position



Sensors and measurement devices for non-contact temperature measurement



Measuring and inspection systems for metal strips, plastics and rubber



Optical micrometers and fiber optics, measuring and test amplifiers



Color recognition sensors, LED analyzers and inline color spectrometers



3D measurement technology for dimensional testing and surface inspection

More Precision

Whether it is for quality assurance, predictive maintenance, process and machine monitoring, automation or R&D – sensors from Micro-Epsilon make a vital contribution to the improvement of products and processes. High precision sensors and measuring systems solve measurement tasks in all core industries – from machine building to automated production lines and integrated OEM solutions.



www.micro-epsilon.com